

COBRAM L65



language

FERRARI

COBRAM L65

Much more advantages.

Kohler engine

with 56 HP and Common Rail supply system.

Electronic adjustment

of the engine rpm, fast and precise through the console on the dashboard.

LED lights

to illuminate the work area even at night or in poor visibility conditions, available as optional.

Swinging OS-Frame

up to 15° to guarantee efficiency and stability on rough grounds.

Hydraulic clutch

with multiple disk in oil-bath for a longer life and less maintenance interventions.



Approved cabs

with A/C and heating system, available as optional.

Dashboard

automotive-styled with colour display.

Joystick

multifunction, electronically-controlled, available as optional.

Hydraulic system

double circuit with independent pumps and high oil flow rate to rear control valves.

Reversibility

of the driving position with platform suspended on silent-blocks.

Driving position

customized for the driver, with all controls within easy reach.

COBRAM L65

Everybody gets his own tractor.

The Cobram L65 range comes in eight versions covering all the classic needs of specialized tractors.

The Cobram L65 tractors are ideal for working in rows of vineyards and orchards, even on slopes thanks to the low centre of gravity and the perfect distribution of weights on the axles, greenhouses and maintenance of both Summer and Winter green spaces.

Available in the version with **central articulation (AR)**, which has the best qualities of agility and manoeuvrability, with **steering wheels (RS)** featuring unparalleled stability and ground grip, or **configured for haymaking (MT)** with an extended platform, the Cobram L65 models have an optional reversible driving position, which is standard on MT.

Approved cab or foldable ROPS complete the outfitting.



Operator's seat

The driving position of the Cobram L65 models is among the best in its class and has been designed specifically for the driver.

The automotive-styled dashboard is full of digital technology: the multifunction colour display - a man-to-machine interface - continuously keeps under control, with top precision, any value of the machine and all diagnostic warning indicators of the machine, in addition to the electro-hydraulically operated logically placed and easy traceable controls.

Reversibility

The versatility of Cobram L65 models is enhanced by the reversibility of the operator's platform, so that the operator can work with a front-mounted implement and steadily supervise all working operations, favouring comfort and safety.

Less than 10 seconds are needed for the operator to turn the driving module consisting of the seat, steering wheel and dashboard by 180°.

The rotary platform is suspended on silent-blocks to dampen all vibrations and highly improves operating comfort.



Engine

Cobram L65 are equipped with a 3-cylinder engine featuring a power of 56 HP. The Common Rail system ensures a precise injection control, a more efficient combustion and less fuel consumption.

A console located to the right of the steering wheel allows the engine revs to be set, stored and recalled at the touch of a button. This is clearly advantageous for the operator, especially for end-of-field manoeuvres in order to bring the engine back from working to low speed and then resume the working speed as soon as he starts the next row of vines.

Cabs

The reversible versions of the Cobram L65 can be equipped with approved cabs equipped with air conditioning and heating to ensure a pleasant liveability throughout the working day.

The large front and rear windows, the large glass doors and the porthole on the rear of the canopy guarantee total visibility of the implement and the roadway, both with traditional and reverse driving positions.

Externally, the cabs have a slender, streamlined profile, without any possibility of holding on to the vegetation, which is essential for working in narrow rows and in crops characterised by dense vegetation.



COBRAM L65

AR

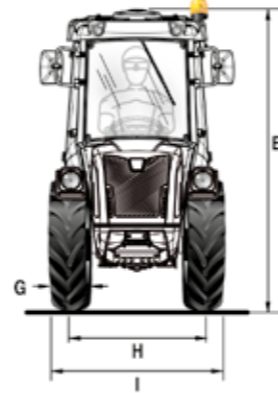
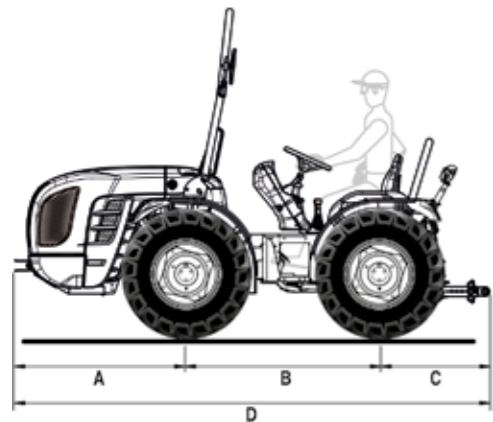

A	B	C	D	E min / max (with roll-bar)	E min / max (with cabin)	F min / max
1216	1390	779	3385	2195 / 2270	2061 / 2106	207 / 266



	8.25-16	210/95-16	250/80-18	280/70R18	320/65R18	260/70R20	31x15.50-15 XTC	31x15.50-15 STG	33x15.50-15 XTC
	with adjustable rim	with adjustable rim	with adjustable rim	with adjustable rim	with adjustable rim	with adjustable rim	with fixed rim	with fixed rim	with fixed rim

G Tyre width (mm)		212	208	240	282	319	258	368	394	391
	H Wheel track min/max (mm)	Mono	794 / 1110	794 / 1110	865 / 1107	869 / 1119	931 / 1119	846 / 1120	1003	1003
Rev		794 / 1110	827 / 1110	865 / 1107	931 / 1119	931 / 1119	902 / 1120	1003	1003	1003
I Width min/max (mm)	Mono	1006 / 1322	1002 / 1322	1105 - 1347	1151 - 1401	1250 - 1438	1104 - 1378	1371	1397	1394
	Rev	1006 / 1322	1035 / 1322	1105 - 1347	1213 - 1401	1250 - 1438	1160 - 1378			

TECHNICAL FEATURES	COBRAM L65 AR
ENGINE	Kohler KDI 1903 TCR
Number of cylinders	3
Displacement (cc)	1,861
Aspiration	Turbo
Fuel system	Direct injection "Common rail"
Emission level	Stage 3B
Power (kW/hp)	42 / 56
Nominal speed (rpm)	2,600
Maximum torque (Nm/rpm)	190 / 1,500
Speed management	Electronically regulated with a console with functions: increase and decrease of engine speed, memorize and recall a particular speed or switch off the electronic throttle and go to the minimum idle speed
Cooling	Water
Tank capacity (lt)	46
CHASSIS	Swinging (up to 15°) integral chassis OS-Frame with central articulation
DRIVE	Four-wheel drive, permanent
TRANSMISSION	Synchronized gearbox: 24 speeds (12 forward and 12 reverse) with synchronized reverser
Movement speed min/max (km/h)	0.8 / 37
Main clutch	Multidisc, in oil bath
DIFFERENTIAL	Front and rear with simultaneous differential lock and electro-hydraulic control
AXLES	Front and rear, with epicyclic reduction units
REAR POWER TAKE-OFF	Independent from the gearbox, 540/540E rpm and synchronized with the gearbox. Engageable under load with brake in disengaged position
PTO clutch	Multidisc, in oil bath
Engagement control	Electro-hydraulic
HYDRAULIC SYSTEM	Double circuit with independent pumps. Optional oversize pumps and heat exchanger
Flow rate to the lift and to the control valves (lt/min)	25.5 (optional oversized pump with flow rate 33.5 lt/min)
Priority flow rate to the hydroguide and to the electro-hydraulic controls (lt/min)	8.5
Max hydraulic pressure (bar)	180
CONTROL VALVES	Mechanical control
Rear (standard)	For lift by rams: 1 double acting For lift with draft and position control: 2 double acting
Rear (optional)	For lift by rams (in addition to the standard ones): 1 single acting and 1 double acting with float or 2 double acting For lift with draft and position control (replacing of the standard ones): 1 single acting and 1 double acting with float
Joystick (available as optional for reversible version only)	With electronic control, including 1 single acting control valve with adjustable flow and free return, 3 double acting control valves (replacing the standard ones), oversized pumps and heat exchanger
REAR LIFT	Standard: by two external rams. Optional: draft and position control
Three-point hitches	Standard: standard couplers cat. 1. Optional: quick couplings cat. 1 or quick couplings cat. 1, L-shaped lift arms, lift rods adjustable in length and hooks adjustable in width
Three-point tie bar	With manual adjustment
Lifting capacity at the end of the arms (kg)	1,510
ELECTRIC SYSTEM	Battery 80 Ah - Alternator 100 A
DRIVING UNIT	Monodirectional with half-platform or Reversible with suspended on silent-block rotating platform and twin pedal assembly
Seat	Standard: comfortable sprung seat adjustable according to the driver's weight, safety belt and 'man on board sensor'. Optional: 'Kab Seating' seat
SERVICE BRAKES	Oil immersed multidisc, acting on the rear transmission, with mechanical control
Parking brake	With handle, acting on the service brakes
STEERING	With hydrostatic steering acting on the central articulation. Flow deviator for steering unit for the reversible version
SAFETY	Standard: front homologated roll-bar, with gas springs for an easy lowering and lifting
CABIN (available as optional for reversible version only)	Homologated and sound-proof, with monocoque body fitted on silent-block device. Ventilation and heating system (Lusso version) or with air conditioning (Comfort version). Glass doors and porthole on rear side of sunroof. Beacon Lamp. Fabric covered seat instead of standard one. Active carbon filter as optional
CONSOLE	Digital type with hour counter, water thermometer and fuel level. Simultaneous reading of engine speed, forwarding speed and PTO speed
TYRES (standard)	8.25-16
Optional	210/95-16 * 250/80-18 * 280/70R18 * 320/65R18 * 260/70-20 * 31x15.50-15 XTC and STG * 33x15.50-15 XTC
TOW HOOKS (standard)	Front and rear CUNA
Optional	Rear rotating or rear adjustable in height (Slider type) tow hooks, both EC approved or CUNA rear adjustable in height (Slider type)
WEIGHT OPERATIONAL	
With roll-bar (kg)	AR monodirectional: 1,585 AR reversible: 1,625
With cabin (kg)	AR reversible: 1,770
OPTIONAL	LED lights, front bumper, beacon lamp, front weight (100 kg) and weights for wheels 18" (45 kg each)

COBRAM L65

RS

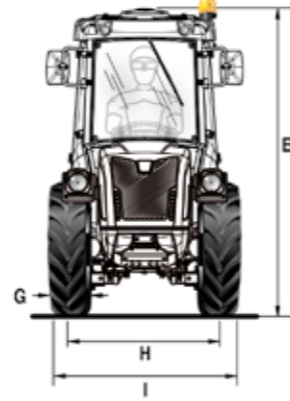
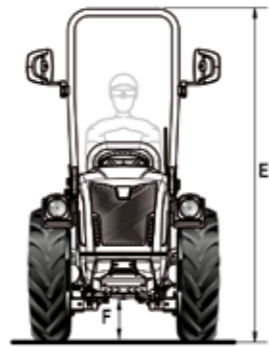
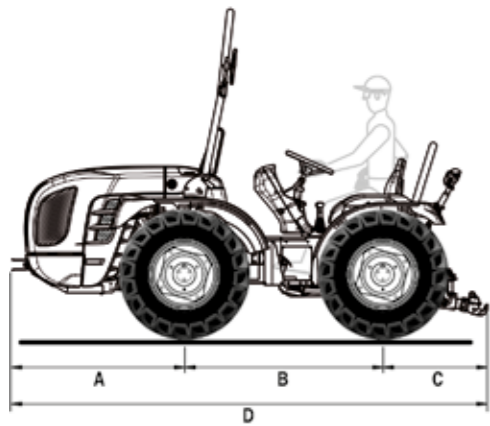

A	B	C	D	E min / max (with roll-bar)	E min / max (with cabin)	F min / max
1216	1390	779	3385	2195 / 2270	2061 / 2106	207 / 266



	8.25-16	210/95-16	250/80-18	280/70R18	320/65R18	260/70R20	31x15.50-15 XTC	31x15.50-15 STG	33x15.50-15 XTC
	with adjustable rim	with adjustable rim	with adjustable rim	with adjustable rim	with adjustable rim	with adjustable rim	with fixed rim	with fixed rim	with fixed rim
G Tyre width (mm)	212	208	240	282	319	258	368	394	391
H Wheel track min/max (mm)	999 / 1305	999 / 1305	996 / 1312	984 / 1324	1074 / 1324	987 / 1325	1100 / 1208	1100 / 1208	1100 / 1208
I Width min/max (mm)	1211 / 1517	1207 / 1513	1236 / 1552	1266 / 1606	1393 / 1643	1245 / 1583	1468 / 1576	1494 / 1602	1491 / 1599

TECHNICAL FEATURES	COBRAM L65 RS
ENGINE	Kohler KDI 1903 TCR
Number of cylinders	3
Displacement (cc)	1,861
Aspiration	Turbo
Fuel system	Direct injection "Common rail"
Emission level	Stage 3B
Power (kW/hp)	42 / 56
Nominal speed (rpm)	2,600
Maximum torque (Nm/rpm)	190 / 1,500
Speed management	Electronically regulated with a console with functions: increase and decrease of engine speed, memorize and recall a particular speed or switch off the electronic throttle and go to the minimum idle speed
Cooling	Water
Tank capacity (lt)	46
CHASSIS	Swinging (up to 15°) integral chassis OS-Frame with steering wheels
DRIVE	Four-wheel drive, permanent
TRANSMISSION	Synchronized gearbox: 24 speeds (12 forward and 12 reverse) with synchronized reverser
Movement speed min/max (km/h)	0.8 / 37
Main clutch	Multidisc, in oil bath
DIFFERENTIAL	Front and rear with simultaneous differential lock and electro-hydraulic control
AXLES	Front and rear, with epicyclic reduction units
REAR POWER TAKE-OFF	Independent from the gearbox, 540/540E rpm and synchronized with the gearbox. Engageable under load with brake in disengaged position
PTO clutch	Multidisc, in oil bath
Engagement control	Electro-hydraulic
HYDRAULIC SYSTEM	Double circuit with independent pumps. Optional oversize pumps and heat exchanger
Flow rate to the lift and to the control valves (lt/min)	25.5 (optional oversized pump with flow rate 33.5 lt/min)
Priority flow rate to the hydroguide and to the electro-hydraulic controls (lt/min)	8.5
Max hydraulic pressure (bar)	180
CONTROL VALVES	Mechanical control
Rear (standard)	For lift by rams: 1 double acting For lift with draft and position control: 2 double acting
Rear (optional)	For lift by rams (in addition to the standard ones): 1 single acting and 1 double acting with float or 2 double acting For lift with draft and position control (replacing of the standard ones): 1 single acting and 1 double acting with float
Joystick (available as optional for reversible version only)	With electronic control, including 1 single acting control valve with adjustable flow and free return, 3 double acting control valves (replacing the standard ones), oversized pumps and heat exchanger
REAR LIFT	Standard: by two external rams. Optional: draft and position control
Three-point hitches	Standard: standard couplers cat. 1. Optional: quick couplings cat. 1 or quick couplings cat. 1, L-shaped lift arms, lift rods adjustable in length and hooks adjustable in width
Three-point tie bar	With manual adjustment
Lifting capacity at the end of the arms (kg)	1,510
ELECTRIC SYSTEM	Battery 80 Ah - Alternator 100 A
DRIVING UNIT	Monodirectional with half-platform or Reversible with suspended on silent-block rotating platform and twin pedal assembly
Seat	Standard: comfortable sprung seat adjustable according to the driver's weight, safety belt and 'man on board sensor'. Optional: 'Kab Seating' seat
SERVICE BRAKES	Oil immersed multidisc, acting on the rear transmission, with mechanical control. Steering brakes on the rear axle driven by two independent pedals
Parking brake	With handle, acting on the service brakes
STEERING	With hydrostatic steering acting on the front wheels. Flow deviator for steering unit for the reversible version
SAFETY	Standard: front homologated roll-bar, with gas springs for an easy lowering and lifting
CABIN (available as optional for reversible version only)	Homologated and sound-proof, with monocoque body fitted on silent-block device. Ventilation and heating system (Lusso version) or with air conditioning (Comfort version). Glass doors and porthole on rear side of sunroof. Beacon Lamp. Fabric covered seat instead of standard one. Active carbon filter as optional
CONSOLE	Digital type with hour counter, water thermometer and fuel level. Simultaneous reading of engine speed, forwarding speed and PTO speed
TYRES (standard)	8.25-16
Optional	210/95-16 * 250/80-18 * 280/70R18 * 320/65R18 * 260/70-20 * 31x15.50-15 XTC and STG * 33x15.50-15 XTC
TOW HOOKS (standard)	Front and rear CUNA
Optional	Rear rotating or rear adjustable in height (Slider type) tow hooks, both EC approved or CUNA rear adjustable in height (Slider type)
WEIGHT OPERATIONAL	
With roll-bar (kg)	RS monodirectional: 1,620 RS reversible: 1,660
With cabin (kg)	RS reversible: 1,800
OPTIONAL	Accumulator for weight compensation with Dual Floating System (only for RS reversible version), LED lights, front bumper, beacon lamp, front weight (100 kg) and weights for wheels 18" (45 kg each)

COBRAM L65 MT

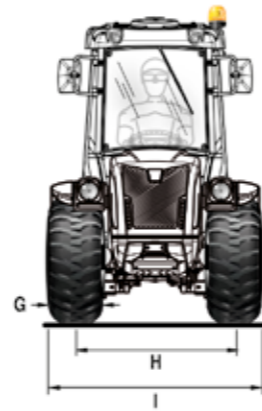
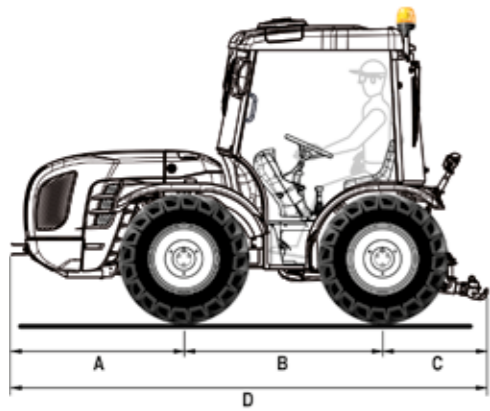

A	B	C	D	E min / max	F min / max
1216	1390	779	3385	2061 / 2081	207 / 266

	31x15.50-15 XTC	31x15.50-15 STG	33x15.50-15 XTC
	with fixed rim	with fixed rim	with fixed rim
G Tyre width (mm)	368	394	391
H Wheel track min/max (mm)	1100 / 1208	1100 / 1208	1100 / 1208
I Width min/max (mm)	1468 / 1576	1494 / 1602	1491 / 1599

TECHNICAL FEATURES	COBRAM L65 MT
ENGINE	Kohler KDI 1903 TCR
Number of cylinders	3
Displacement (cc)	1,861
Aspiration	Turbo
Fuel system	Direct injection "Common rail"
Emission level	Stage 3B
Power (kW/hp)	42 / 56
Nominal speed (rpm)	2,600
Maximum torque (Nm/rpm)	190 / 1,500
Speed management	Electronically regulated with a console with functions: increase and decrease of engine speed, memorize and recall a particular speed or switch off the electronic throttle and go to the minimum idle speed
Cooling	Water
Tank capacity (lt)	46
CHASSIS	Swinging (up to 15°) integral chassis OS-Frame with steering wheels, configured in haymaking version
DRIVE	Four-wheel drive, permanent
TRANSMISSION	Synchronized gearbox: 24 speeds (12 forward and 12 reverse) with synchronized reverser
Movement speed min/max (km/h)	0.8 / 37
Main clutch	Multidisc, in oil bath
DIFFERENTIAL	Front and rear with simultaneous differential lock and electro-hydraulic control
AXLES	Front and rear, with epicyclic reduction units
REAR POWER TAKE-OFF	Independent from the gearbox, 540/540E rpm and synchronized with the gearbox. Engageable under load with brake in disengaged position
PTO clutch	Multidisc, in oil bath
Engagement control	Electro-hydraulic
HYDRAULIC SYSTEM	Double circuit with independent pumps. Optional oversize pumps and heat exchanger
Flow rate to the lift and to the control valves (lt/min)	25.5 (optional oversized pump with flow rate 33.5 lt/min)
Priority flow rate to the hydroguide and to the electro-hydraulic controls (lt/min)	8.5
Max hydraulic pressure (bar)	180
CONTROL VALVES	Mechanical control
Rear (standard)	1 double acting and 1 double acting with float
Rear (optional)	2 double acting (replacing of the standard ones)
REAR LIFT	By four external rams with accumulator for weight compensation HDR and Dual Floating System®
Three-point hitches	Standard: standard couplers cat. 1. Optional: quick couplings cat. 1 or quick couplings cat. 1, L-shaped lift arms, lift rods adjustable in length and hooks adjustable in width
Three-point tie bar	With manual adjustment
Lifting capacity at the end of the arms (kg)	1,510
ELECTRIC SYSTEM	Battery 80 Ah - Alternator 100 A
DRIVING UNIT	Reversible with suspended on silent-block rotating platform and twin pedal assembly
Seat	Comfortable sprung seat adjustable according to the driver's weight, safety belt and 'man on board sensor'
SERVICE BRAKES	Oil immersed multidisc, acting on the rear transmission, with mechanical control. Steering brakes on the rear axle driven by two independent pedals
Parking brake	With handle, acting on the service brakes
STEERING	With hydrostatic steering acting on the front wheels. Flow deviator for steering unit
SAFETY	Standard: semi-cabin with beacon lamp
CABIN (available as optional for reversible version only)	Homologated and sound-proof, with monocoque body fitted on silent-block device. Ventilation and heating system (Lusso version) or with air conditioning (Comfort version). Glass doors and porthole on rear side of sunroof. Beacon Lamp. Fabric covered seat instead of standard one. Active carbon filter as optional
CONSOLE	Digital type with hour counter, water thermometer and fuel level. Simultaneous reading of engine speed, forwarding speed and PTO speed
TYRES (standard)	31x15.50-15 XTC
Optional	31x15.50-15 STG * 33x15.50-15 XTC
TOW HOOKS (standard)	Front and rear CUNA
Optional	Rear rotating or rear adjustable in height (Slider type) tow hooks, both EC approved or CUNA rear adjustable in height (Slider type)
WEIGHT OPERATIONAL	
With semi-cabin (kg)	MT reversible: 1,730
With cabin (kg)	MT reversible: 1,800
OPTIONAL	LED lights, front bumper, front weight (100 kg)

THE SERVICES



SPARE PARTS

A complete range of original spare parts, guaranteed directly by the manufacturer.



ASSISTANCE

A team of specialists, well prepared and available to assure an efficient and resolving service.



WARRANTY

A precise certainty for the customer's satisfaction: 2-year warranty included in the price.



LUBRICANTS

We recommend to use the original PowerLube lubricants.



FINANCIAL SERVICES

Financial solutions to meet the credit requirements.



M A D E I N I T A L Y



BCS S.p.A.

Viale Mazzini, 161 - 20081 Abbiategrasso (Milano)

Tel. +39 02 94821 - info@bcs-ferrari.it

www.ferrariagri.it

